

2

1

B

B

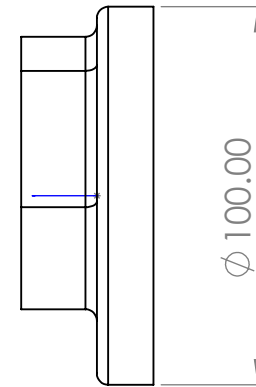
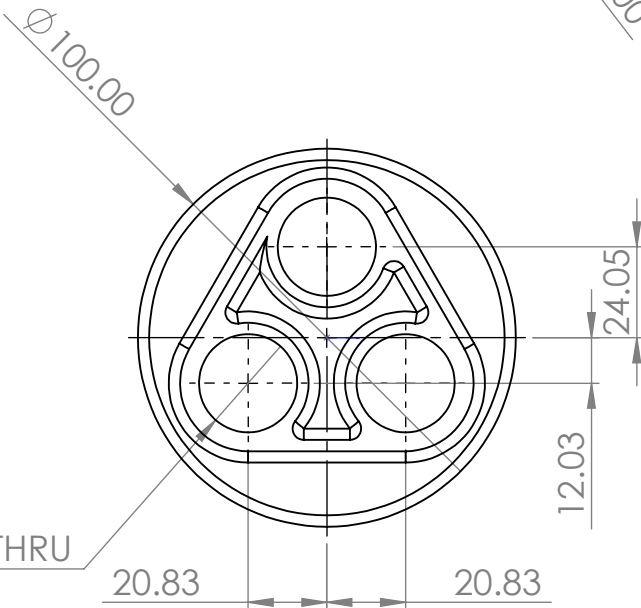
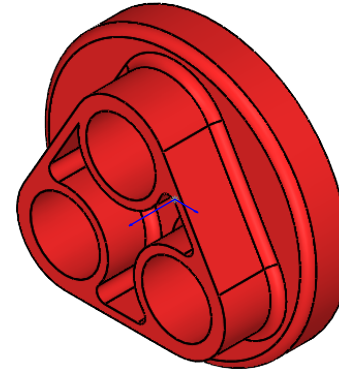
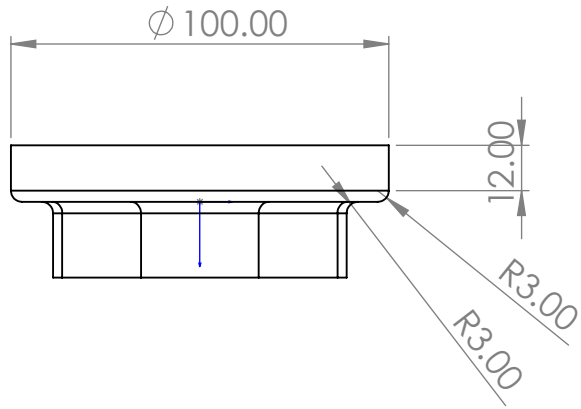

A

A

UNLESS OTHERWISE SPECIFIED:

DIMENSIONS ARE IN INCHES  
 TOLERANCES:  
 FRACTIONAL  $\pm$   
 ANGULAR: MACH  $\pm$  BEND  $\pm$   
 TWO PLACE DECIMAL  $\pm$   
 THREE PLACE DECIMAL  $\pm$

INTERPRET GEOMETRIC  
 TOLERANCING PER:

MATERIAL

FINISH

DO NOT SCALE DRAWING

NAME DATE

DRAWN

CHECKED

ENG APPR.

MFG APPR.

Q.A.

COMMENTS:

<COMPANY NAME>

TITLE:

SIZE DWG. NO. REV  
**SINGLE PART TWO**

SCALE: 1:2

SHEET 1 OF 1

**PROPRIETARY AND CONFIDENTIAL**  
 THE INFORMATION CONTAINED IN THIS  
 DRAWING IS THE SOLE PROPERTY OF  
 <INSERT COMPANY NAME HERE>. ANY  
 REPRODUCTION IN PART OR AS A WHOLE  
 WITHOUT THE WRITTEN PERMISSION OF  
 <INSERT COMPANY NAME HERE> IS  
 PROHIBITED.

NEXT ASSY

USED ON

APPLICATION

2

1